

HI-DEF

INSPECTION SYSTEMS



SENSOR[®]
NETWORKS, INC

Inspection, Testing & Asset-Integrity Solutions

366 Walker Drive, Suite 200 • State College, PA 16801

(814) 466-7207 • SensorNetworksInc.com

Offices in Houston, Hong Kong, and Osaka

Version 3.0

Insight Into Your Assets

What you don't know about your critical plant assets and infrastructure can develop into significant risks. Sensor Networks, Inc. delivers the visual inspection tools you need to see inside and inspect process and pressure components for cleanliness and mechanical damage; helping you assess conditions and retrieve loose parts.



process



utilities



environmental



oil & gas



aerospace

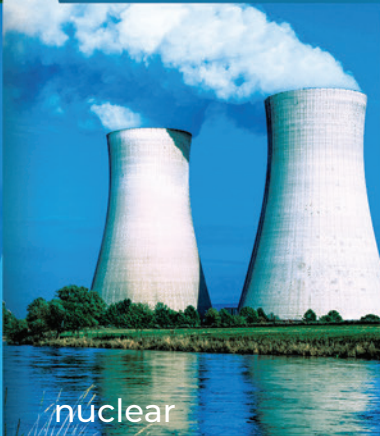

nuclear

Table of Contents

- Introduction 2-3
- PTZ Systems 4
- About HDTV 5
- Hi-Def PTZ's 6-7
- Tech Exposed 8-9
- Retrieval Tools 10-11
- Specifications 12

Innovation

At Sensor Networks, we combine new technologies with novel approaches to monitoring asset integrity, giving you advanced tools to keep your systems operating safely, productively, and efficiently.

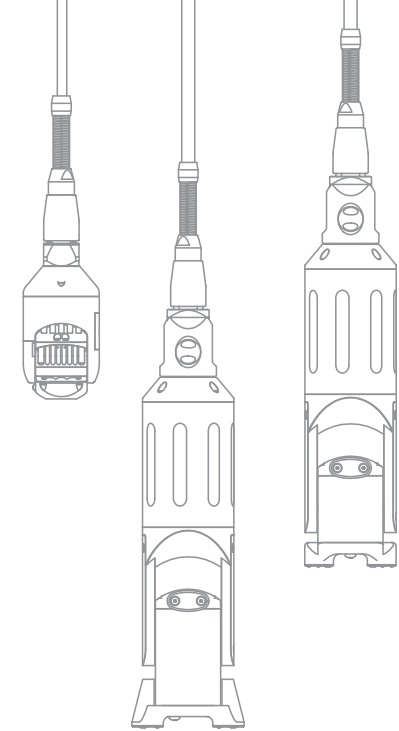

Expertise

Drawing on more than 90 years of combined experience in visual inspection across a range of industrial sectors, our team takes the guesswork out of applications engineering. Trust us to bring the best technologies and techniques to bear on your inspection challenges.

Reliability

More than thirty Fortune 500 companies already rely on our technology and team to gain better insight on their critical infrastructure.



Hi-Def Systems

Understanding HD

All Sensor Networks RVI tools are now Hi-Def



- Versatile lightweight solution for control room shelf
- Full-control user interface for Pan-Tilt-Zoom-Lighting
- All cable connections on rear panel
- UL-rated low voltage power supply
- Magnetic swivel mount for monitor or recorder
- One power cord, no additional outlets needed

Modular System

Integrated System



- Integrated one-hand carry solution
- Full-control user interface for Pan-Tilt-Zoom-Lighting
- Stores camera head for transport
- Stores and winds 150 feet (45m) of cable
- Swivel mount for monitor or recorder
- One power cord, no additional outlets needed

6:1 Pixel Improvement

345,600 pixels is typical of Standard Video vs. 2,073,600 for HDTV. That's a 6:1 ratio improvement just in pixel resolution not to mention HDTV's significantly improved color fidelity.

Resolution

High definition television offers a much higher resolution than standard definition video. While a typical analog broadcast in the U.S. contains a maximum of 525 horizontal lines of resolution, an HDTV signal supports over 1000 HTVL (1920 Horizontal pixels).

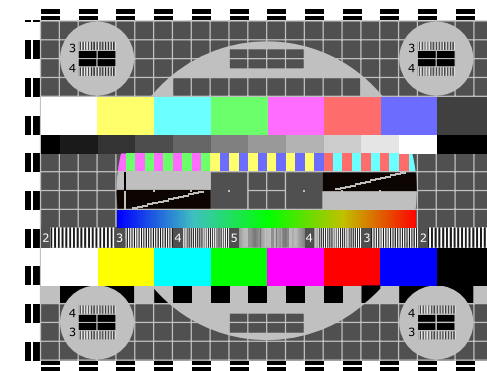

Video test-pattern charts like this one are used to assess the camera system's ability to accurately translate color.

Aspect Ratio

While previous broadcasts used a 4:3 ratio (4 units wide for every 3 units tall), HDTV uses a ratio of 16:9. This wider aspect ratio more closely emulates how humans see the world, making the image appear more realistic.

Color Rendition

HDTV systems provide precise and vivid representation of color. This is important for certain industrial inspections where subtle color variations become meaningful to the examination.

HDTV - 1080p (1920 x 1080)

HDTV - 720p (1280 x 720)

NTSC DVD
(720 x 480)

This chart shows a simplified comparison of NTSC (Standard Video) in lower-left corner compared with medium resolution (720p) and high-res full HDTV (1080p).

HD | 1920x1080

4x

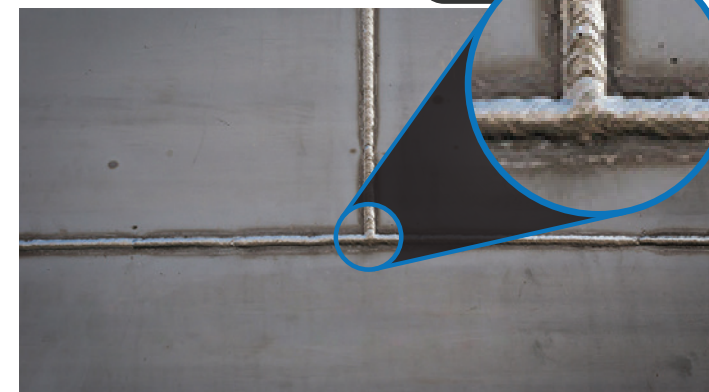

SD | 720x480

4x

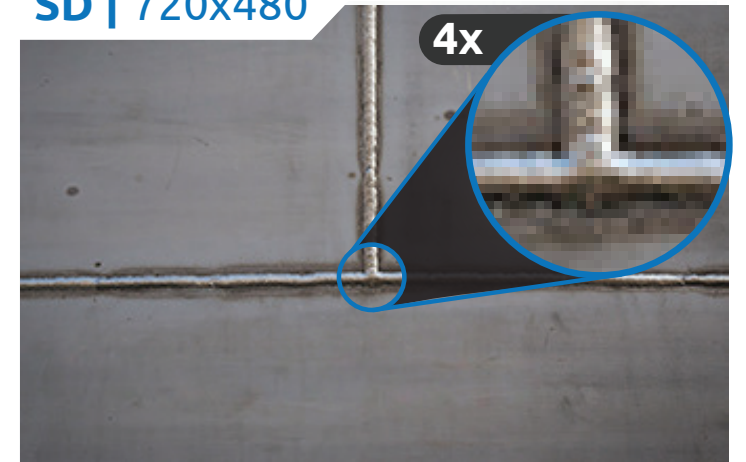

Hi-Def PTZx

PTZx includes everything you need to perform tank, vessel or large-area inspections of piping and facility infrastructure. Even with 100 feet of cable, cable reel, monitor and digital recorder, this system weighs under 30 lbs. (14 kg) and can be carried with one hand. The result of decades of RVI experience, PTZx is rugged, reliable, waterproof and easy-to-use.



variable-speed pan with 360-degree continuous rotation

corrosion-resistant nickel-plated aluminum with stainless steel

submersible to 100 ft (30m)

integral & optional auxiliary LED lamps

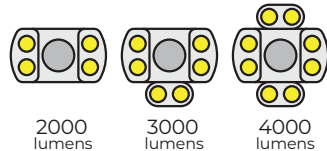

2000 lumens

3000 lumens

4000 lumens

30x or 10x optical zoom

high-res camera with sensitivity control for reflective surfaces

variable-speed 270 degree tilt (244 degree for Hi-Def PTZx35)

digital video recorder & monitor

- 7 in (178mm) FHD display
- Records 1080p video in ProRes® or DNx format
- 64 GB SD card
- Microphone

control unit

- 150 ft (45m) reel or modular
- Adjustable zoom lens
- Auto/manual focus
- Adjustable light intensity
- Adjustable video brightness
- Camera position memory
- Image control

Hi-Def 3.0

Hi-Def 4.3

Hi-Def 3.5

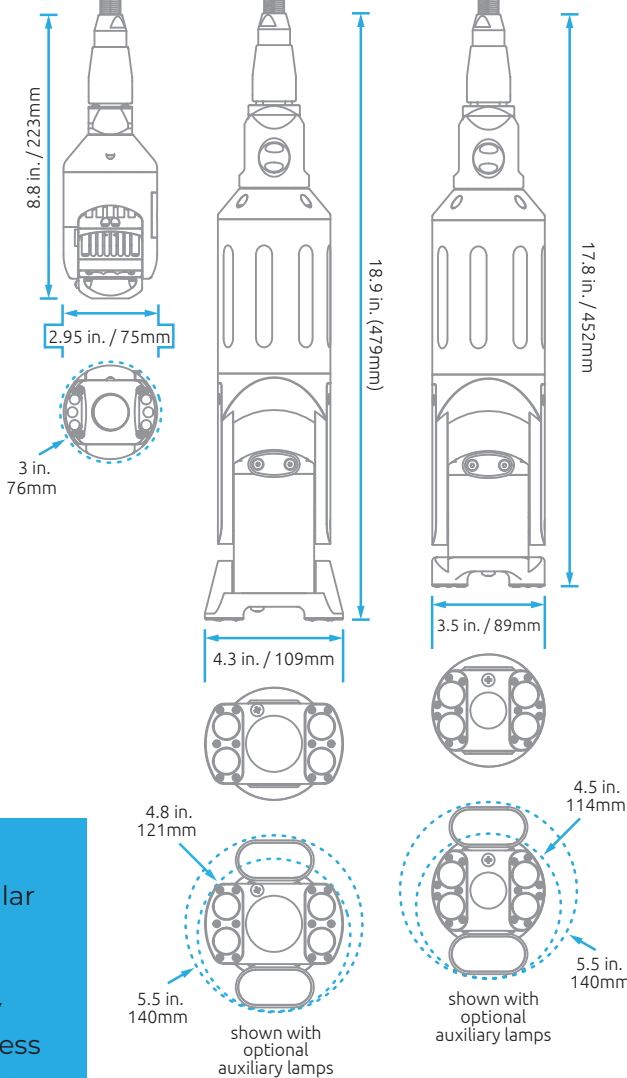

applications

Nuclear Power: Reactor pressure vessel and cooling pumps, steam generator channel head, nozzle welds, fuel pool, fuel assembly, spent fuel, IWE/IWL exams.

Fossil Power: FAC & MIC inspections, baffle plates, HP steam headers, tank and vessels.

Refining & Petrochemical: Tray-towers, refractory- and glass-lined vessels, tanks, pipe racks, heat exchanger internals, baffle plates.

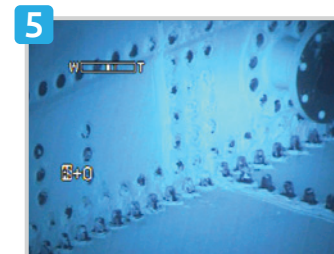
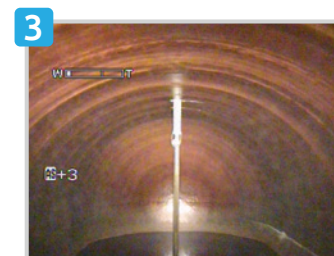
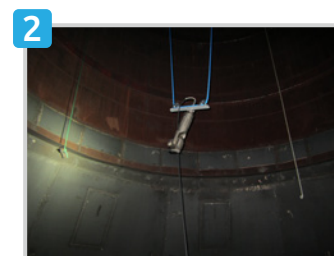
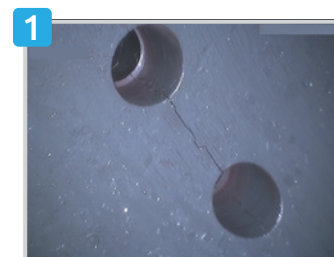
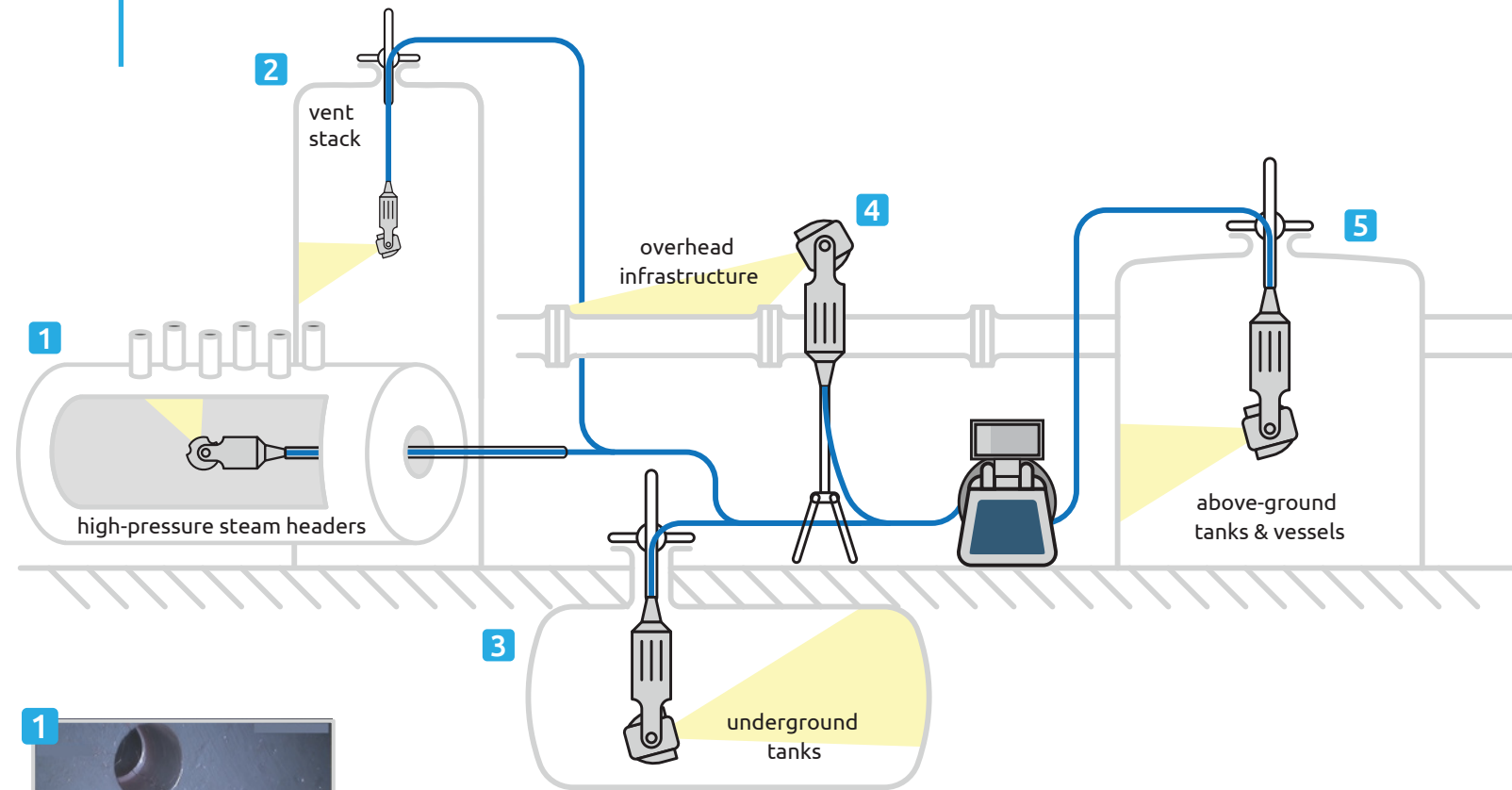

lowering pole

- 6 ft (1.8m) length each
- connect two or more

tank flange mount

- mounts to flanged openings Ø 4-24 in.
- clamps pole to stabilize camera at any angle

lifting hoist ring

- mounts to pole end
- attaches to safety lanyard

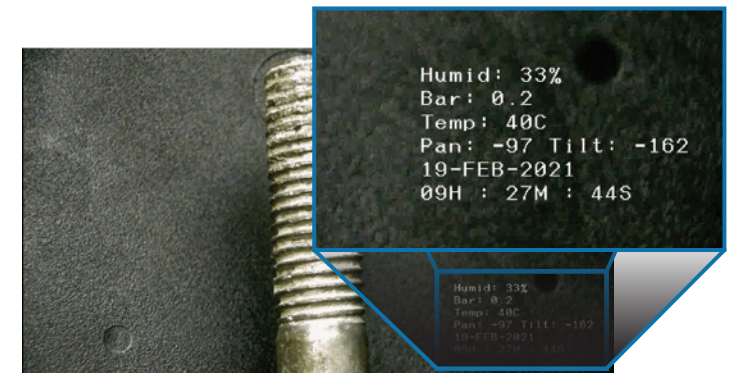

PTZ text overlay with data

Hi-Def PTZTMX

TECHNOLOGY EXPOSED

12 precision-engineered reasons to specify SNI's Hi-Def Pan-Tilt-Zoom product line

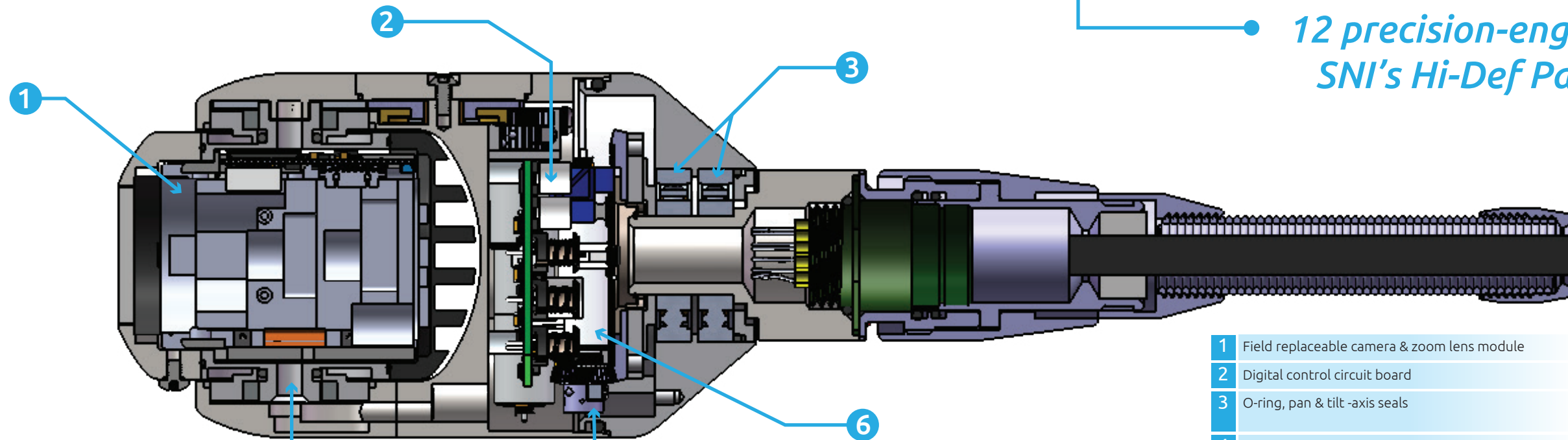

2.95in (75mm) Ø head shown 1:1 scale (can pan & tilt in a 3 in. ID cylinder)

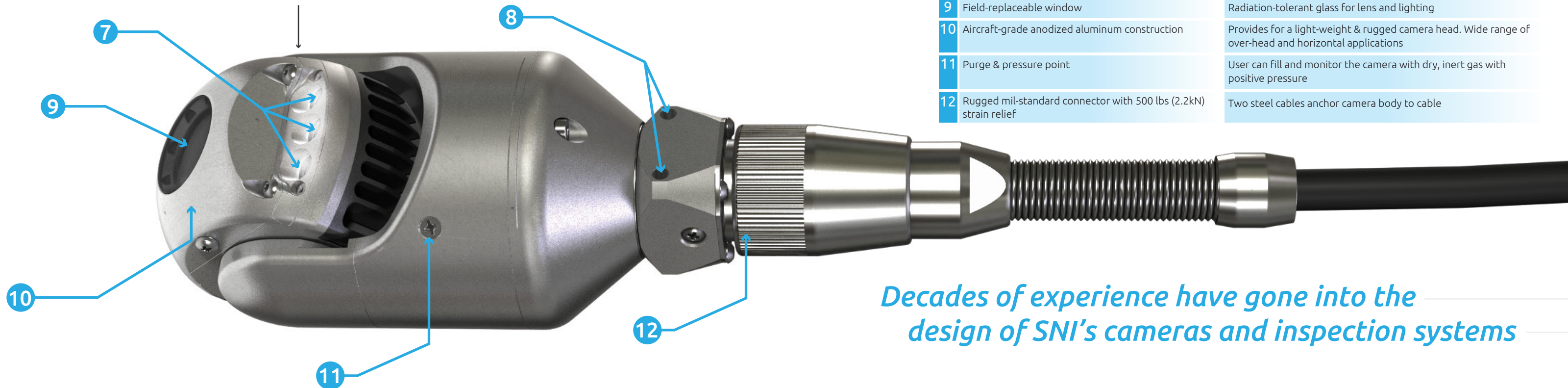

- | | | |
|----|--|---|
| 1 | Field replaceable camera & zoom lens module | User can easily replace the camera module due to radiation failure |
| 2 | Digital control circuit board | Tested & improved radiation tolerance |
| 3 | O-ring, pan & tilt-axis seals | Reliable, time-tested, design allows for use at up to 100 ft. (30m) submerged in water |
| 4 | Rotary sensors on tilt and pan axis | Monitor, recorder, or frame grabber displays pan & tilt position |
| 5 | Miniature slip clutches | Clutch-protected drivetrain protects motors for manual positioning |
| 6 | High-energy, rare-earth magnet DC motors/gearboxes | Enables a small, compact and rugged pan & tilt gimbal |
| 7 | Broad-spectrum white LED lighting | Wide-angle and narrow-angle lighting for close and far viewing |
| 8 | M6-Threaded mounting points | Easily attach the PTZ head to tooling or robotic end-effectors |
| 9 | Field-replaceable window | Radiation-tolerant glass for lens and lighting |
| 10 | Aircraft-grade anodized aluminum construction | Provides for a light-weight & rugged camera head. Wide range of over-head and horizontal applications |
| 11 | Purge & pressure point | User can fill and monitor the camera with dry, inert gas with positive pressure |
| 12 | Rugged mil-standard connector with 500 lbs (2.2kN) strain relief | Two steel cables anchor camera body to cable |

Decades of experience have gone into the design of SNI's cameras and inspection systems

loose parts retrieval tooling

JAWS 2.0 (left) and RGT (right) through 1.5D elbows in 4" and 6" (100 & 150 mm), respectively

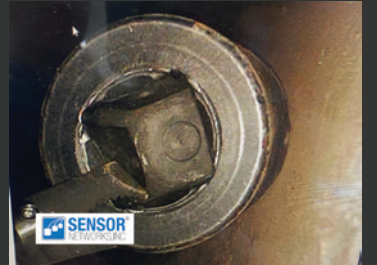

Large 1 in. drive impact socket retrieval with RGT

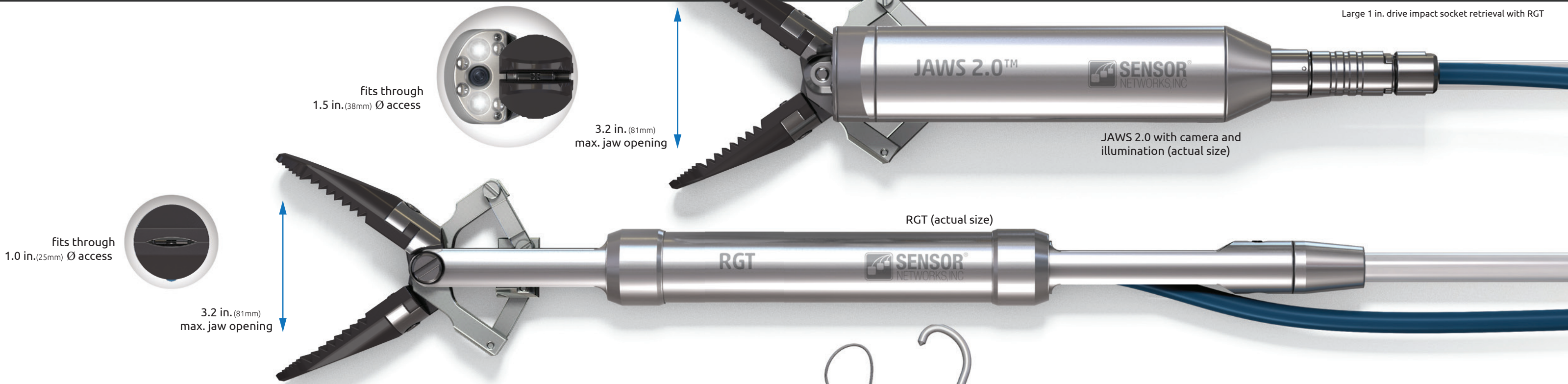

Fits through 1.5 in. (38mm) Ø access

3.2 in. (81mm) max. jaw opening

JAWS 2.0 with camera and illumination (actual size)

RGT (actual size)

Fits through 1.0 in. (25mm) Ø access

3.2 in. (81mm) max. jaw opening

jaws

left to right: serrated jaws, long serrated jaws, curved serrated jaws, fork & tine, needle nose, magnet, snare, hook, sampling cups



RGT controls



JAWS 2.0 controls

delivery devices

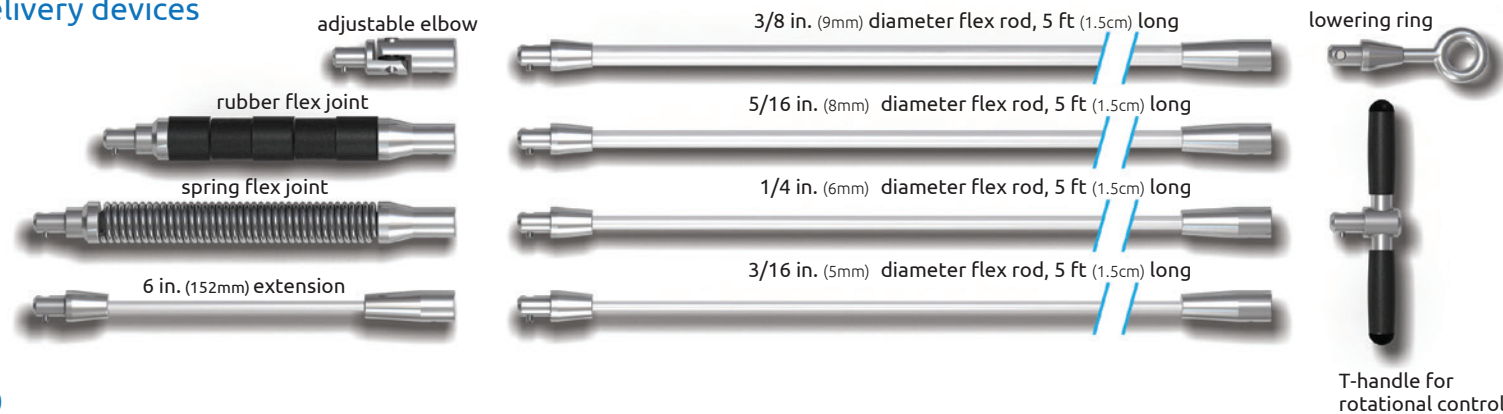

adjustable elbow

rubber flex joint

spring flex joint

6 in. (152mm) extension

3/8 in. (9mm) diameter flex rod, 5 ft (1.5cm) long

5/16 in. (8mm) diameter flex rod, 5 ft (1.5cm) long

1/4 in. (6mm) diameter flex rod, 5 ft (1.5cm) long

3/16 in. (5mm) diameter flex rod, 5 ft (1.5cm) long

lowering ring

T-handle for rotational control

JAWS 2.0 basic kit **blue items included**
14×22×8 in, 12 lb (5.5kg)



JAWS 2.0 ultimate kit **all contents**
15½×25×8½ in, 19 lb (8.6kg)



kits:

standard components: JAWS 2.0 HD grabber • JAWS 2.0 HD display/controller • AC adapter/charger • operator manual • 50 ft (15m) power/video cable • 50 ft (15m) power/video extension cable

Jaw Sets: short serrated jaws • fork and tine • flat serrated jaws • sampling cups • curved serrated jaws • tool adapter • needle-nose jaws

tools: snares: sm & lg • magnets: sm & lg (w/case) • hooks: sm, med, lg, xl (four) hooks: sm, med, lg, xl

Diameter/Length	6 in. (15cm)	12 in. (30cm)	16 in. (40cm)	5ft (1.5m)
Ø3/16 in. (5mm)			1	10
Ø1/4 in. (6mm)			1	10
Ø5/16 in. (8mm)	1	1	1	10
Ø3/8 in. (9mm)			1	10

accessories: tee handle • adjustable elbow • rubber and spring flex joints • hoist lifting ring

misc.: hex keys • screws • quiver

Hi-Def 3.0

Hi-Def 3.5

Hi-Def 4.3

video	optical / digital zoom	10x / 12x	10x / 12x	30x / 12x
	effective imager pixels	2.13 mega-pixels	2.13 mega-pixels	2.13 mega-pixels
	sensitivity	0.5 lux	0.5 lux	0.5 lux
	horizontal FOV (wide - tele)	W 54° / T 4.9°	W 54° / T 4.9°	W 59° / T 2.1°
	brightness adjustment	±7 step	±7 step	±7 step
	minimum focus distance	W 0.01m / T 1.0m	W 0.01m / T 1.0m	W 0.01m / T 1.2m
lighting	type	integral, long-life LED lamps		
	lumens (adjustable)	1500	2000	2000
	auxillary lighting	N/A	1,000 lumens x2	1,000 lumens x2
mechanical	minimum access hole	3.0 in. (76 mm)	3.6 in. (90 mm)	4.4 in. (110 mm)
	head weight	2.4 lbs. (1.1 kg)	6 lbs. (2.7 kg)	6 lbs. (2.7 kg)
	material	anodized aluminum	anodized & nickle-plated aluminum	
	temperature range (in degrees)	14 to 120°F (-10 to 49°C)		
	pressure rating	44 PSI (3 bar), 100 ft (30 M) of water		
	internal purge & pressurization	inert or dry air up to 10 psi (0.7 bar)		
	pan range (degrees)	±180	360 continuous	360 continuous
	tilt range (degrees)	±135	±135	±122
	radiation life expectancy	50,000 RAD average total dose [†]		
	system	weight with 100' cable	25 lbs. (11.4 kg)	29 lbs. (13.2 kg)
# boxes		one with two handles		
cable length		50 ft - 500 ft (15 - 150 M)		
control units options		modular (desktop) or cable reel with slip-rings		
power requirement		110-240 VAC; 4 A; 50/60 Hz		
outputs		2 HDMI, 12 VDC accessory power		
other	text overlay with keyboard	time & date, pan & tilt, zoom, temperature, pressure, & humidity (internal), image title		
	single-button home position	saved pan, tilt, & zoom positions		

JAWS 2.0™

RGT

tool head	construction	aluminum, stainless steel	type	12V NiMH	tool head	construction	stainless steel		
	diameter	1.4 in.(34 mm)	size	9.0×5.5×2.4 in.		diameter	0.82 in. (21 mm)		
	access required	1.5 in.(38 mm)	weight	3.1 lbs. (1.4 kg)		access required	1.0 in. (25 mm)		
	length	7.1 in.(180 mm)	features	HD color 5 in. display, HDMI video output, battery gage, grip strength indicator		length	11.3 in. (287 mm)		
	push point connector	10 mm quick-disconnect	camera	1/3 in. color CMOS (1920×1080 pixels)		push point connector	10 mm quick-disconnect		
	weight	0.7 lbs. (0.3 kg)		viewing angle		88° hor., 63° vert., 140° diag.	weight	0.7 lbs. (0.32 kg)	
	jaw opening	3.2 in.(81 mm)	lighting	2 long-life LEDs, total 150 lumens		jaw opening	3.2 in. (81 mm)		
	jaw clamping force	25 lbs. at tip	cable	cable material		polyurethane	jaw clamping force	25 lbs. at tip	
	end-effectors	see chart*				cable dia.	3/16 in.(4.5 mm)	end effectors (3)	curved serrated, flat serrated, fork and tine
	Radiation Life Expectancy	30,000 Rad Avg. Total Dose [†]				cable length	50 ft (15 m) with extensions		
cable	cable material	TPE	power supply	type	Lithium-Ion rechargeable				
	cable dia.	1/4 in.(6 mm)		size	7.0×4.8×2.7 in.				
	cable length	50 ft(15 m) with extensions		weight	1 lb. (0.5 kg)				
			features	battery gage					

* Basic kit comes standard with one serrated jaw.
Options include a curved serrated, fork & tine, needle-nose pliers, sampling cups, hooks and manual tool adapter.
[†] Camera replacement module available

Sensor Networks is a registered trademark of Sensor Networks, Inc. ©2021. All rights reserved.
Hi-Def PTZ™ and JAWS 2.0™ are Trademarks of Sensor Networks, Inc.
JAWS 2.0 is patent pending.