

# Deployment of Cellular-Based Ultrasonic Corrosion Measurement System for Refining & Petro- Chemical Plant Applications

Sean Lynch - Philadelphia Energy Solutions  
James Barshinger -Sensor Networks, Inc.  
Michael Nugent -Equity Engineering Group

# Outline

- Historic Overview
- Evolution of TML's and CML's
- Intrusive vs Non-Intrusive
- Cellular Corrosion Monitoring System
- Applications
- Field Trials
- Conclusion

# Tell-Tale Tell-Tail

## Historic Perspective

- Pipe Gaging
- Tell-Tale Drilling
- “D” Meter
- Corrosion Probes
- API 570 and proliferation of TML’s

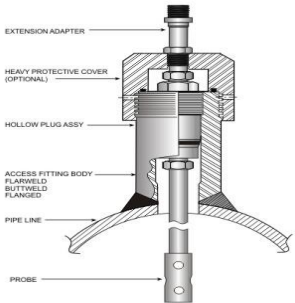
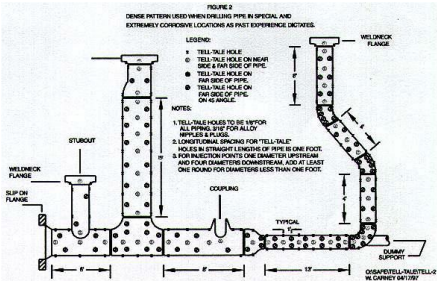

Corrosion Probe System

# Pipe Gaging and Tell Tale Drilling

- Drill holes in pipe through corrosion allowance, Usually 1/8"
- Desire to have a “weeper” or “pilot” before larger release
- Still in use at some refineries

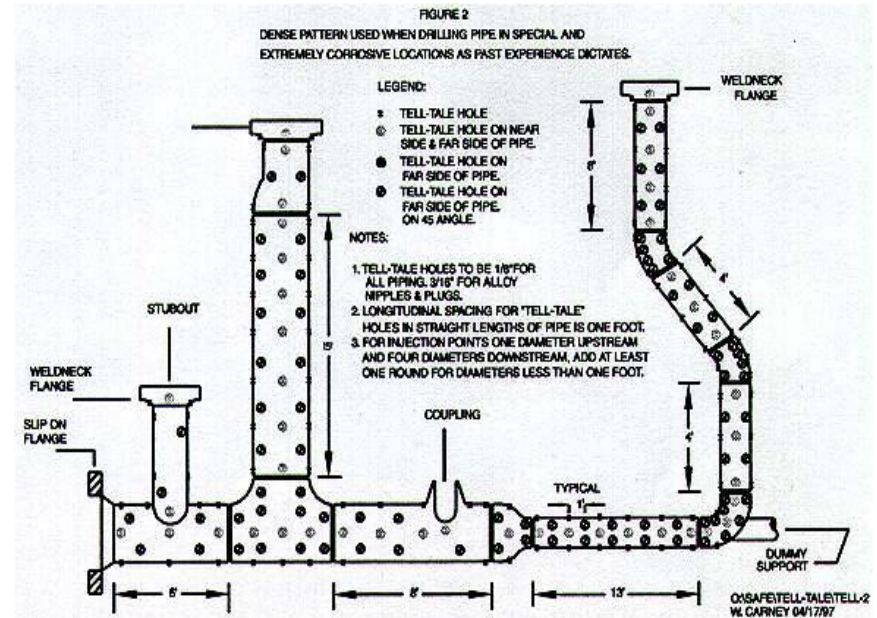

# Historic Methods

- Tell-Tales
  - Still in use today
  - Sometimes to Corrosion Allowance
  - Sometimes to  $\frac{1}{4}$  t or T min
- Goal was for small indicator before major release



# Corrosion Probes

- Measure change in electrical resistance of wire as it corrodes in stream
- Usually different metallurgy, shear stress than pipe
- Sometimes high infant mortality rate
- Can be challenging to replace on line even if retractable

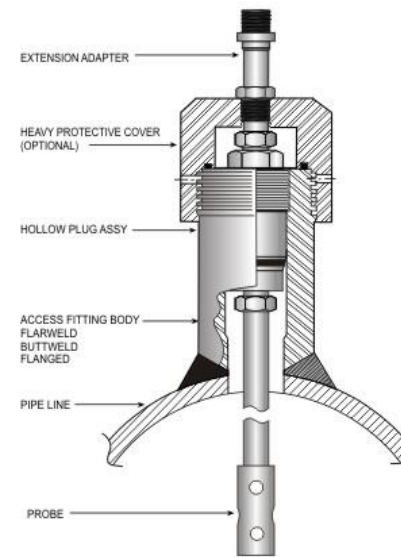

**Corrosion Probe System**



# TML Proliferation

- Good idea taken to extremes
- Some sites have >3,000,000 TML's
- Repeatability, Variation and Growths
- Manpower Intensive and more and more difficult
- Moderate site estimate of 25,000 TML's over 3 years to be \$75 per TML



# Manual Spot UT Thickness Can provide False Confidence

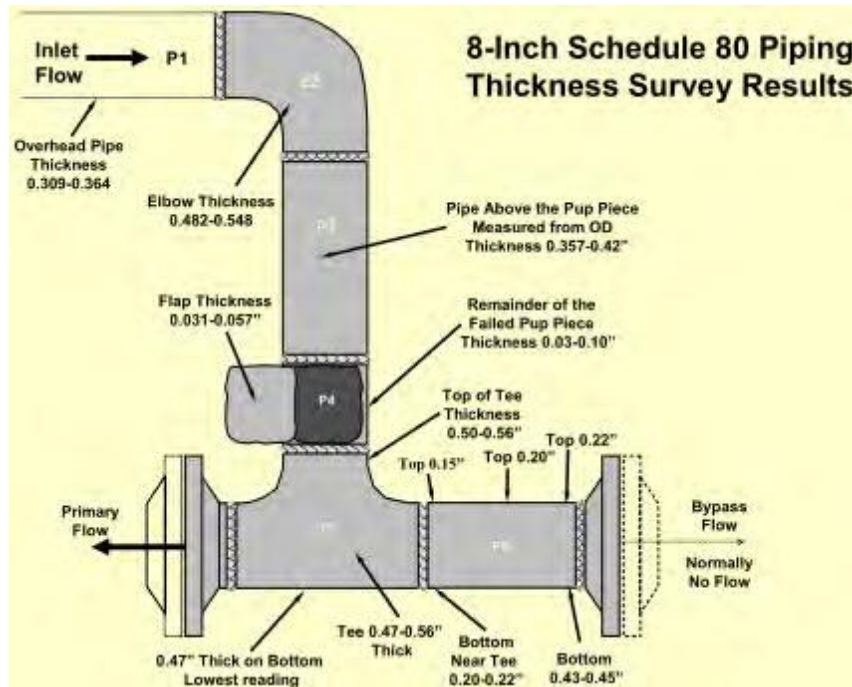



# Non-Intrusive UT Systems Attributes

1. Non-intrusive, Versatile & Safe
2. Modular
3. Portable / battery operation
4. Non-reliant on IT depts.
5. Accurate including Temp Sensing
6. Easy access to the data
7. Cost effective

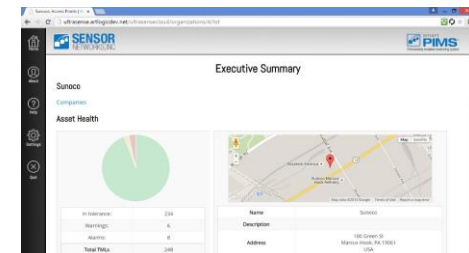
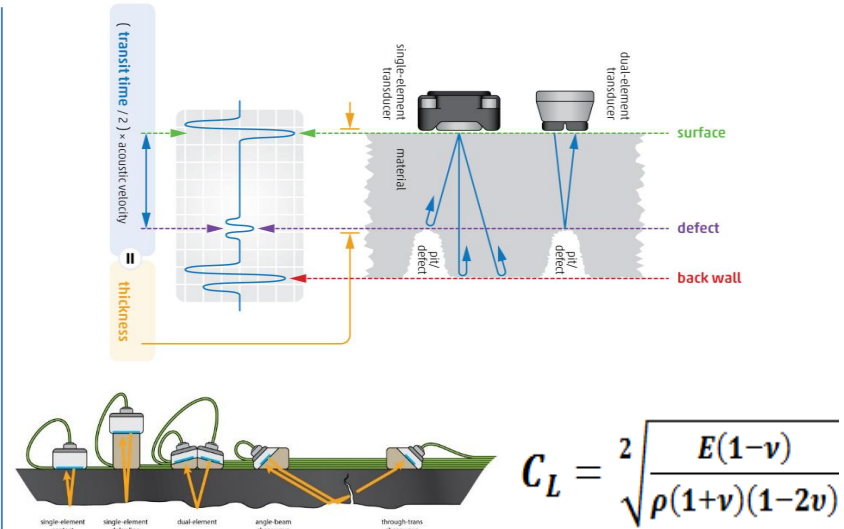

# System Topology

- Wired or wireless.
- Common back-end data management software.
- Many sensors-points per system.
- Technology is the enabler.



# Web-based Data Management

- Auto archiving & record retention simplicity
- Alarms & Warnings via e-mail
  - Min T and Max rate
  - Ex.  $< 1.1$  mm or  $> 0.01$  mm / week
- Corrosion-rate calculation
- Automated reporting and e-mail alerts
- Google Maps & GPS asset location
- Accessible from any web-browser device

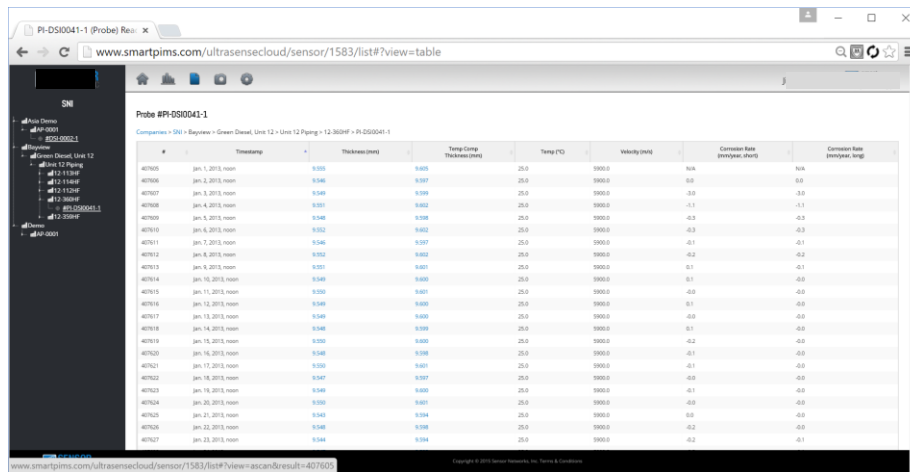
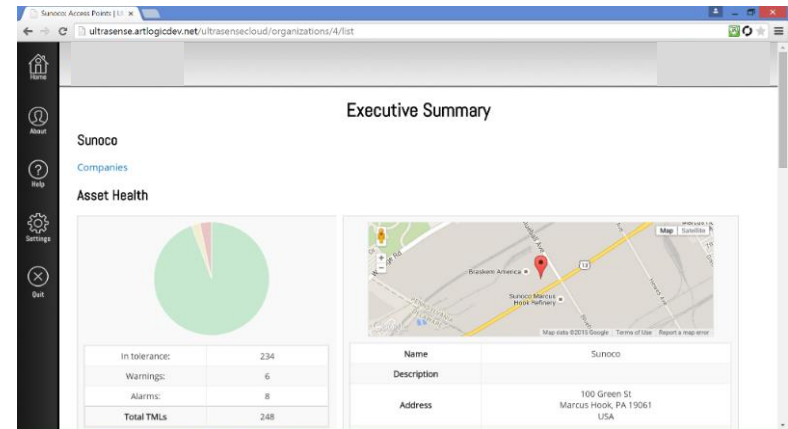

# Installed Sensors can be Customized

- Conventional Wall Thickness
- Pit Growth
- Crack Growth

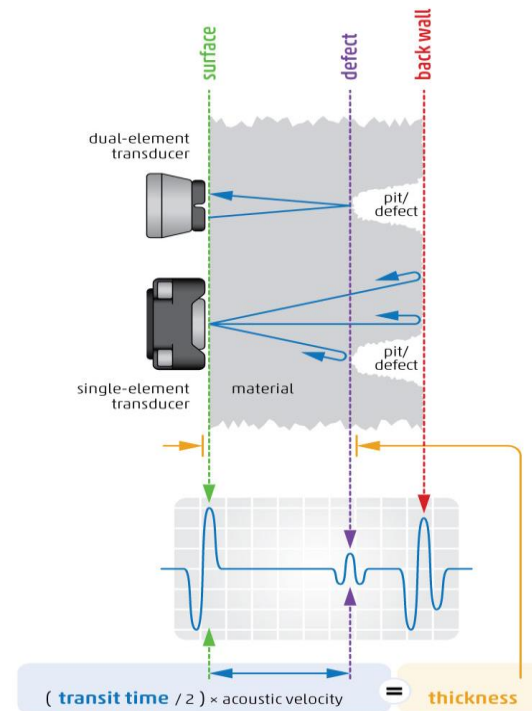
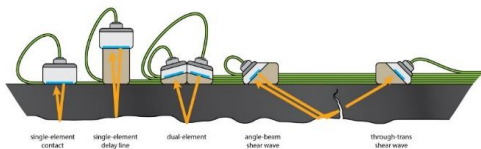

# Refinery Deployments

# Atmospheric Gas-Oil Line Monitoring

**Overview:** to extend life to next turn-around and make sure that line is no longer corroding.

**Application:** Atmospheric gas-oil, ~270C (520F)

- 3" Sch 40, subject to severe but uniform corrosion, most piping is < ½" nominal wall





# Atmospheric Gas-Oil Line Monitoring

## Product Used:

- smartPIMS HT Cellular w/ 4 HT probes temporarily attached, managed by on-site service provider
- Monitoring interval: 4 hours
- Data is monitored & trended daily using webPIMS
- Installation time: 6 hours

**Outcome:** Refinery able to safely monitor process piping which was not scheduled to be repaired during outage and trend for future metal loss conditions



# Results

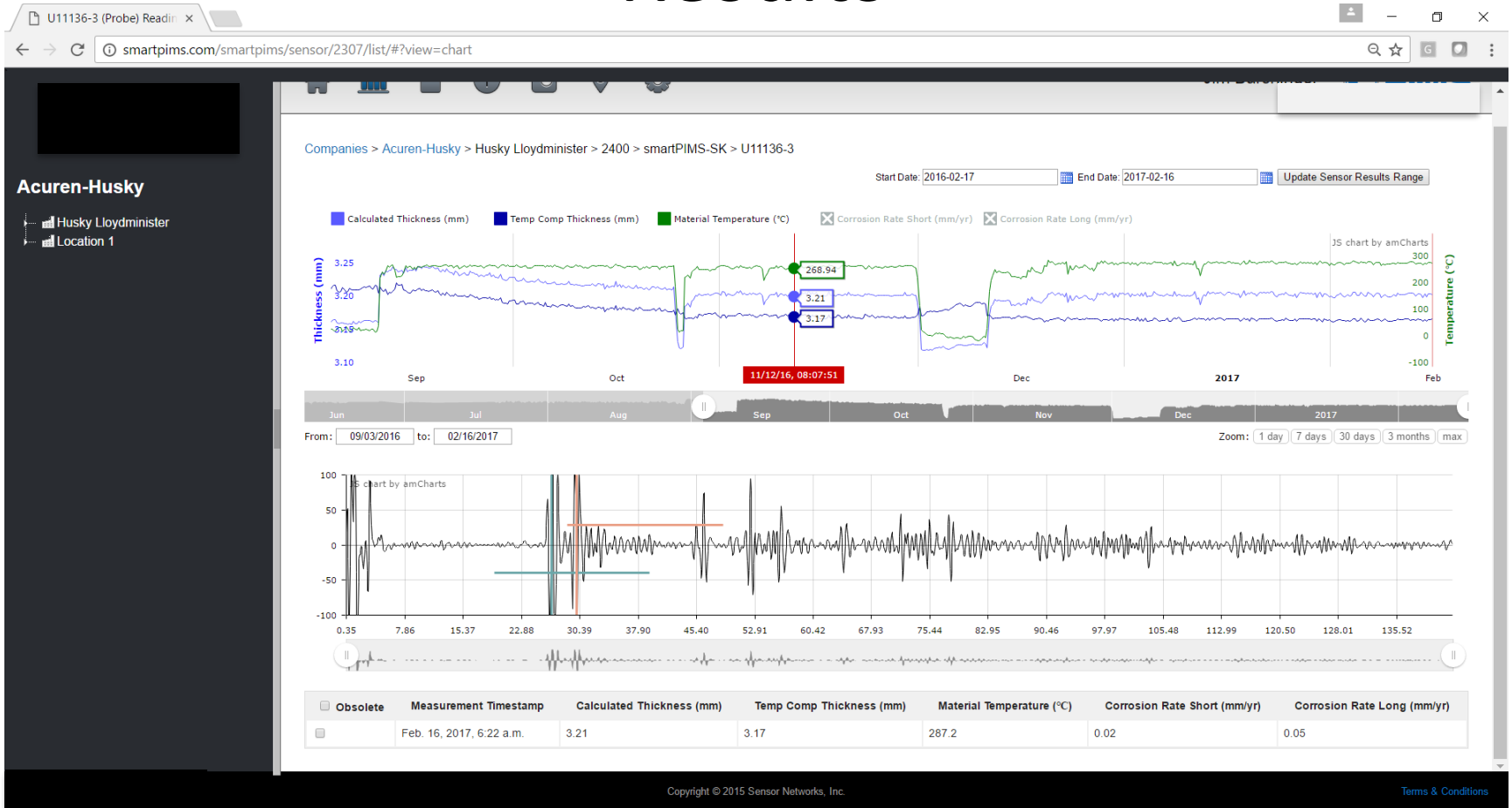

- 0.02mm/yr S.T., 0.05mm/yr L.T. corrosion rate
- Temp compensated data used for calculation

# Hydro-Fluoric (HF) Alky Unit Monitoring

**Overview:** sending NDT technicians to inspect the top of the HF Alky unit daily to monitor specific low spots to ensure wall loss did not exceed minimum required rate before outage planned in 6 months

**Application:** HF Alky Unit (HF Isostripper OVHD elbow), ~65C (150F)

- 24" Sch. 40 ... most piping is <math>< \frac{1}{2}</math>" nominal wall but measured at ~0.300" with pitting and general "low spots"



# Hydro-Fluoric (HF) Alky Unit Monitoring

## Product Used: smartPIMS Cellular

- smartPIMS LT Cellular w/ 8 dual element probes temporarily attached, managed by refinery maintenance team
- Monitoring interval: 12 hours
- Data is monitored & trended daily using webPIMS
- Installation time: 4 hours

## Outcome: Objectives achieved:

- Safety – kept personnel from climbing & cumbersome inspection positions on tower
- Economic – saved >\$365K in inspection cost
- Easy to install/monitor, accurate & semi-permanent solution



# Results

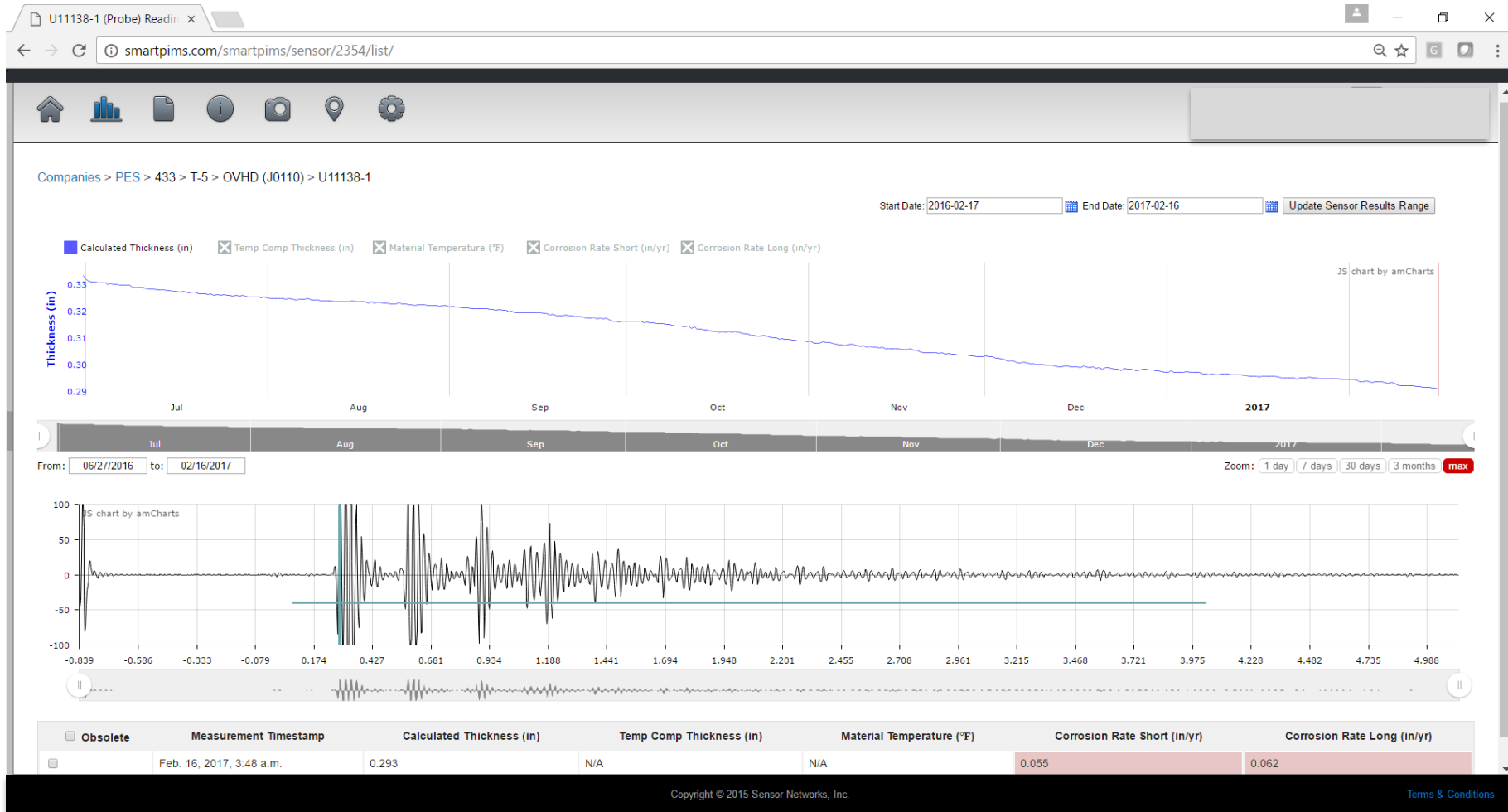

- 55mpy S.T, 62mpy L.T.



# Vacuum Fractionator

**Overview:** Customer built new unit to increase production. H<sub>2</sub>S line prone to corrosion at two different 90's before overhead line. Elected to use non-intrusive permanently installed UT sensors to monitor pipe intrados, extrados, top & bottom locations in lieu of installing a heat trace to maintain dew point.

**Application:** Vacuum Fractionator ~150C (300F)

- 12" Sch. 40 ... all nominal wall thickness .4" +/- 12%

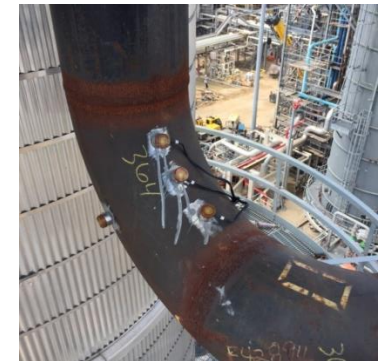



# Vacuum Fractionator

## Product Used: smartPIMS Cellular

- smartPIMS LT Cellular w/ 8 dual element probes permanently attached
- Monitoring interval: 1 reading every 2 days, transmission every 6 days. Battery life ~4 yrs.
- DSI bolted to hand rail and unistrut, cables run to TMLs

## Outcome:

- Inspection costs – lift, scaffolding, or rope access required to reach locations 60' and 100' high
- Process control – access to more ... accurate and quality data to trend corrosion rates
- Heat trace & insulation would have cost 12x more than installed UT sensors



# Crude Overhead Line

## Overview:

- Customer installed new overhead lines connecting units.
- Lines located in un-accessible areas and wanted data on corrosion rates and inspection needs.
- Customer installed permanently installed UT sensors to monitor pipe intrados, extrados, top & bottom locations

**Application:** Crude Overhead Line 100C-38C  
(310F-100F)

- 12" Sch. 40 ... all nominal wall thickness .4"  
+/- 12%

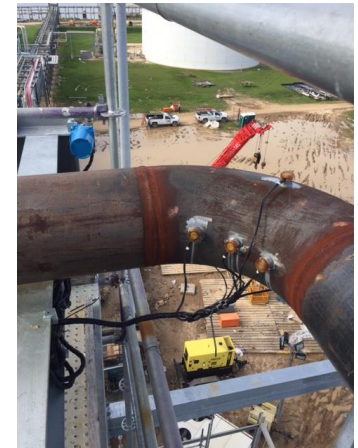

# Crude Overhead Line

## Product Used: smartPIMS Cellular

- smartPIMS LT Cellular w/ 8 dual element probes permanently attached
- Monitoring interval: 1 reading every 2 days, transmission every 6 days. Estimated battery life ~4 yrs.
- DSI bolted to hand rail and unistrut, cables run to TMLs

## Outcome:

- Inspection costs – lift, scaffolding, or rope access required to reach locations 40' off the ground
- Process control – access to more ... accurate and quality data to trend corrosion rates



# Non-Cellular Deployments

## Process Control of offshore oil & gas production

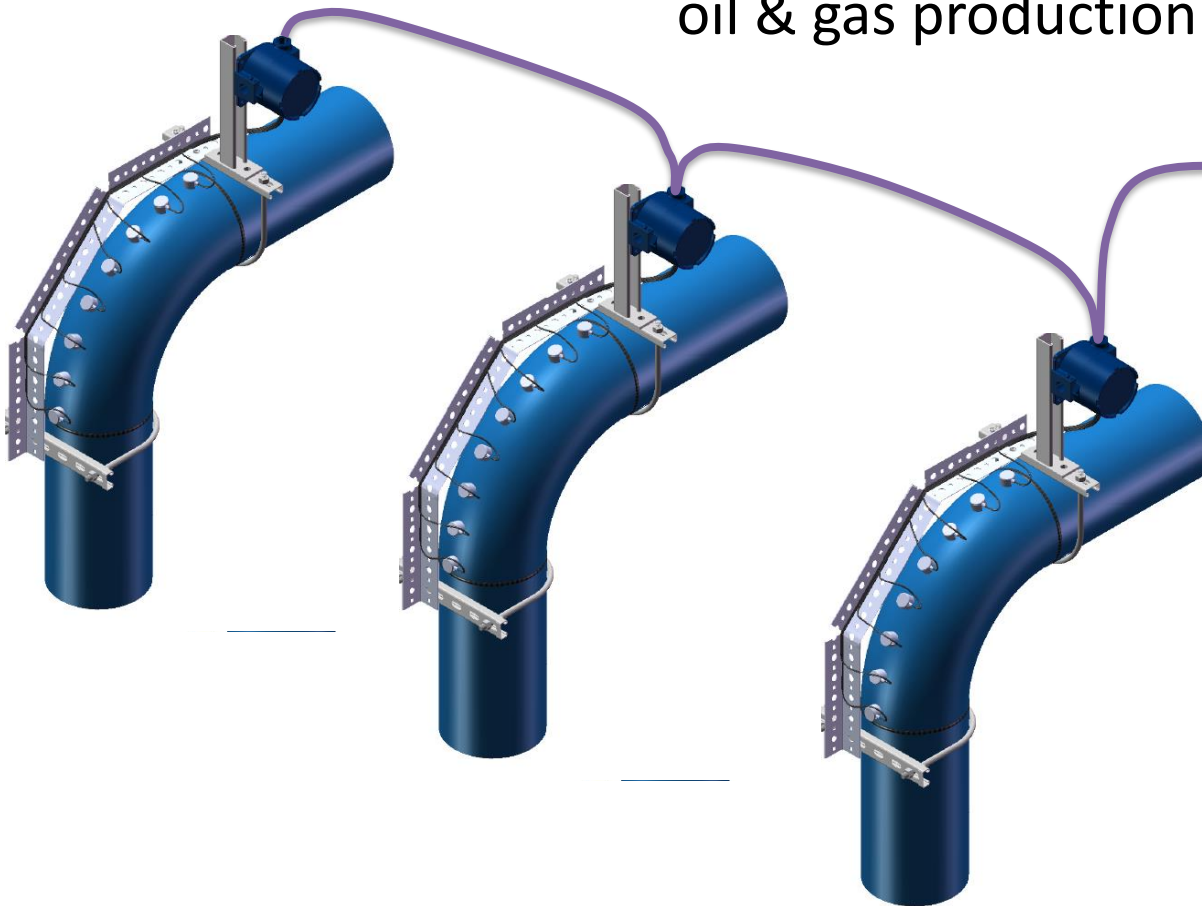

- Sand erosion monitoring
- Eight – sixteen UT thickness monitoring sensors per pipe elbow extrados
- Monitor from 10 mm down to 1 mm with 25  $\mu$  resolution
- 1 – 32 transmitters per single cable network tied directly to control room's DCS



# Pipeline Integrity

**Overview:** An ILI report showed a number of low spots at three separate locations along a 100' stretch of gas pipeline. When the previous ILI was performed 7 years prior, these low spots did not exist. The operator not only wanted data to tell if the corrosion was episodic or in nature or active but also did not want to fix/repair the pipeline and did not want to perform another ILI on a shorter interval. After mapping the internal corrosion on the pipeline, installed sensors were deployed to monitor the low spots along the excavated line.

**Application:** Monitoring pits low spots instead of fix/repair

- 30" natural gas transmission line nominal ~.300"
- Low spots ranging from .120" to .240" – buried

**Product Used:** smartPIMS Modbus configuration w/ 8, 25' dual element probes permanently attached and buried to monitor "low spots" as identified by masses screening

- Sensors were attached via epoxy & stopaq and buried
- Enclosure used to house DSI & act as collection point for techs
- Operator will vary frequency of manual readings

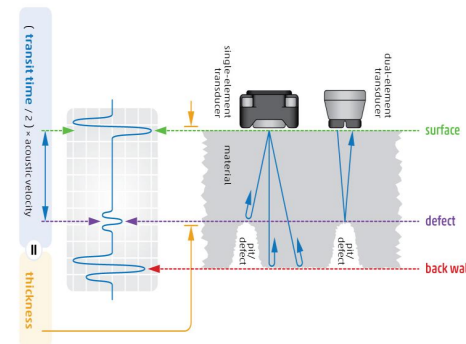



# Conclusions

- Better Data on Continuous Basis
- Can be Monitored locally or remotely
- Able for temporary installation without welding
- Short Term data obtained faster
- Sensors can be moved easily prior to attachment
- More economic and safer for personnel than manual UT even on short term basis

# Questions?



**Jim Barshinger**

**President**

Sensor Networks, Inc.

176-500 Technology Drive

Boalsburg, PA , 16827, USA

814-441-2476 (cell)

[www.installedsensors.com](http://www.installedsensors.com)

**Michael Nugent**

**Principal Engineer**

The Equity Engineering Group

PO Box 912

Westwood, NJ 07675

Office: 1-201-497-6935

Mobile: 1-201-446-6693

[mjnugent@equityeng.com](mailto:mjnugent@equityeng.com)